

KEY FEATURES

- Interpolated 3-axis cartesian system
- Freestanding cantilever structure
- Pre-loaded zero backlash axes
- Available working area ranging from 400x400xmm to 800x600mm
- Vertical axes (Z) from 100 to 300mm long
- Maximum transportable tool weight 12 kg
- Repeatability 0.05mm
- Precision 0.08mm
- Proprietary programming pc software included
- 16in-16out general purpose available

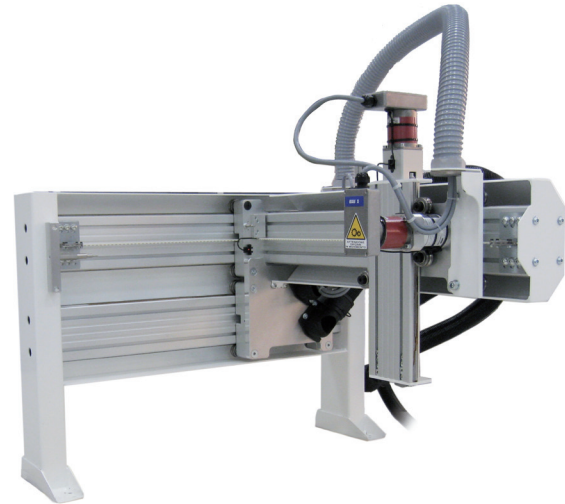

The TETRABOT Cartesian robot with freestanding cantilever structure is designed to be easily and quickly installed on automated lines for the construction of many automated applications (e.g. dispensing or screwing).

TETRABOT represents a key-product for both manufacturers and integrators since:

- The working area is modular and customizable (ranging from 400x400mm to 800x600mm)
- It guarantees the installation of applications up to 12 Kg on the Z-axis
- The programming is extremely simple, thanks to the ALPHA electronics and the proprietary software
- It offers several channels for the robot-assembling line interaction: through the 16-input and 16-output general purposes available (controlled via external PLC for example), through the RS232 serial port or via bus CAN Open.

Its solid steel-bearing structure, the self-powered trailers made in anticorodal aluminium alloy, the roller guides on steel rails, the axes pre-loaded in order to have zero backlash and the bipolar stepper motors enhance the robot extreme precision and high reliability during movements.

Tetrabot's design is smooth and appealing thanks to the epoxy powder coating, the machined billet aluminium parts, the built-in fittings for cables, pipes and other accessories. These features improve furthermore the installation and start-up user friendliness of the robot.

Tetrabot is controlled through the AEB Robotics ALPHA system. This powerful PC-compatible programming proprietary software stands out for its intuitive and simple programme settings that allow to carry out complex operations in a short time.

In particular, the importing of .dxf, Excel and Gerber files together with the display of the interface data in tabular or 3D-graphic mode simplify the operator work.

The programmes set are stored in the robot memory. Afterwards, the device can be controlled from the automation line via CAN Open, serial RS232 or through the 16in. and 16out.

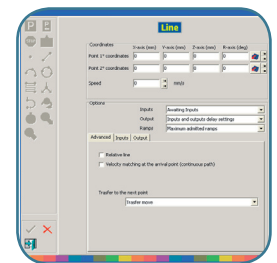

Settings

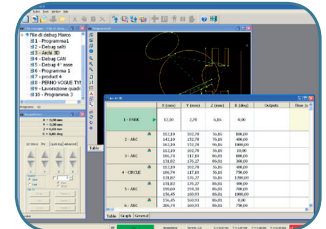

Tabular display

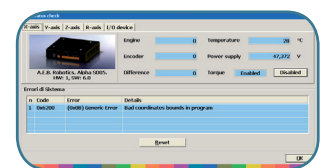

Diagnosis



TETRABOT

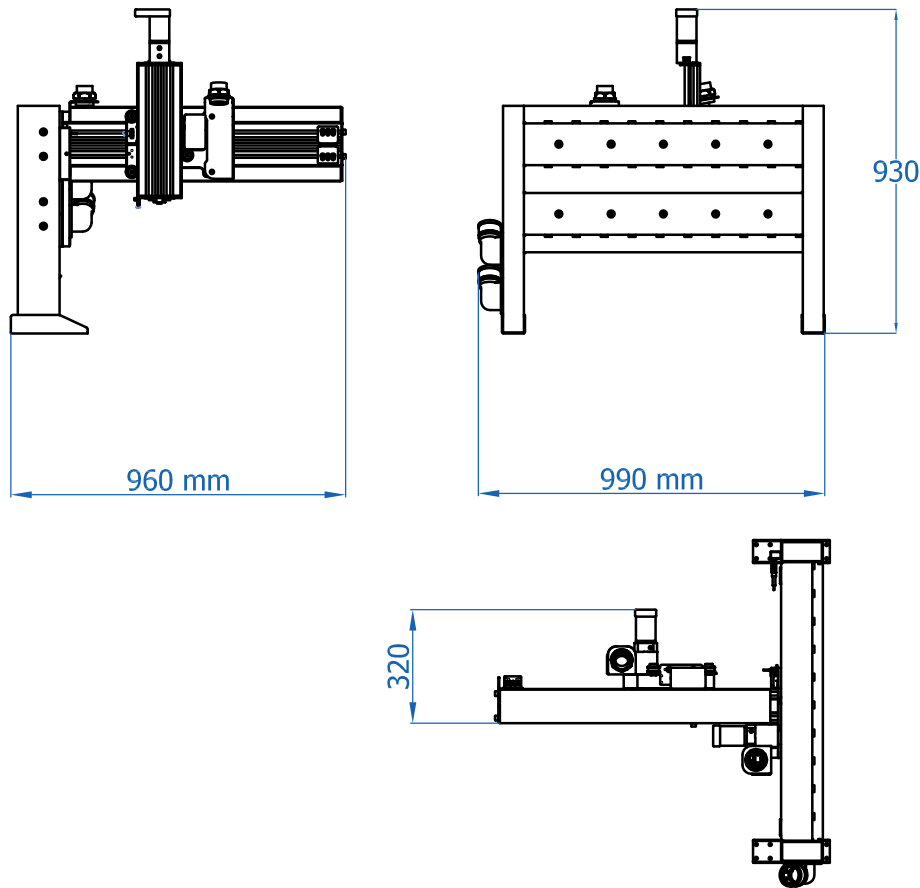

The drawing refers to a model work area 600x400x140 mm

AXIS MOTION SYSTEM	Interpolated 3-axis Cartesian system with bipolar stepper motors
REPEATABILITY	0,05 mm
PRECISION	0,08 mm
TRANSPORTABLE LOAD	tool 12 kg
PTP SPEED	1-400 mm/sec X, Y, Z
INTERPOLATION	Linear and 3D circular on X, Y, Z Point-to-point and Continuous path
AVAILABLE I/O	16 digital input - 16 digital output general purpose 11 control input, 7 status outputs
PROGRAMMING	Remote mode (self-learning) through PC software. Profiles imported from DXF, Excel and Gerber files
CONTROLLING	- ALPHA CP control panel - RS232 - CanOpen® - IO
ON-BOARD MEMORY	100,000 points; 255 programmes
POWER SUPPLY	110/230Vac ±10% - 50/60Hz - 400VA
DIMENSIONS AND WEIGHT (600X400X140mm model)	960x990x930mm, 50Kg

- Wrist rotation on Z axis
- ALPHA CP control panel
- X-Y-Z setting system
- Brake on z-axis
- External cabled electric panel
- PROFIBUS connection through CAN Open/PROFIBUS gateway

- Work area X axis: from 400 to 800 mm
Y axis: from 400 to 600 mm
Z axis: from 100 to 300 mm
- Toolholder predisposition included

For the purpose of making continuous improvements to the product, all characteristics are subject to change without prior notice.



Via dell'Industria 20
42025 - Cavriago - Italy

tel. +39 0522 494404
fax. +39 0522 494410

info@aeb-robotics.com
www.aeb-robotics.com