

Off-line Filter Units**FNA 008 · FNA 016**

Operating pressure up to 4 bar / 58 psi · Nominal flow rate up to 19 l/min / 5.0 gpm



Off-line Filter Unit

Description**Application**

In the by-pass flow of hydraulic and lubrication systems.

Performance features*Protection against wear:*

By means of filter elements that meet the highest demands regarding cleanliness class and dirt-holding capacity.

Protection against failure:

By means of continuous partial filtration, excellent cleanliness classes can be achieved. Machine failures, due to contamination, are reduced, maintenance and oil change intervals are extended.

Special design features*Housing cover:*

The cover can be opened without special auxiliary tools.

Compact:

The unique cover design allows that the filter element can be changed without losing any oil. No pipes are needed except for the connection lines. The filter units feature low power consumption and minimal operational noise.

Pressure relief valve:

An integrated PRV (pressure relief valve) protects against overload.

Dirt retention valve:

At the bottom of the filter element, flow through from inside to outside, there is a dirt retention valve. This closes while pulling the filter element, which is hung up at the cover, out of the housing. Sedimented dirt is removed together with the filter element. Because of the cover design, filter element change can be carried out almost without losing any oil.

Filter elements

Flow direction from inside to outside. The star-shaped pleating of the filter material results in:

- › large filter surfaces
- › low pressure drop
- › high dirt-holding capacities
- › particularly long maintenance intervals

Filter maintenance

By using a clogging indicator, the correct moment for maintenance is stated, what guarantees optimum utilization of the filter life.

Materials

Pump housing: Aluminum alloy
 Filter housing: Steel
 Cover: Aluminum alloy
 Seals: NBR (FPM on request)
 Filter media: EXAPOR®MAX 2 - inorganic, multi-layer microfiber web

Accessories

Water-absorbing filter elements EXAPOR®AQUA are available on request.

With Part No. FNA 008.1700, a mounting set is available, that facilitates the fitting of incoming and outgoing pipes onto an existing filling / venting connection.

For installation in filter cooling circuits, a version with by-pass valve is available on request.

Electrical and / or optical clogging indicators are available on request.

Dimensions and technical data see catalog sheet 60.20.

Characteristics

Nominal flow rate

Up to 16 l/min at $v = 35 \text{ mm}^2/\text{s}$ /
up to 4.2 gpm at $v = 162 \text{ SUS}$
(see Selection Chart, column 2)

Connection

Threaded port according to ISO 228 or DIN 13.
Sizes see Selection Chart, column 9 and 10

Filter fineness

3 $\mu\text{m(c)}$... 10 $\mu\text{m(c)}$
 β -values according to ISO 16889
(see Selection Chart, column 3 and Diagram Dx)

Dirt-holding capacity

The dirt-holding capacity values in grams from the ISO MTD test dust are in accordance with the ISO 16889 requirements (see Selection Chart, column 4).

Hydraulic fluids

Mineral oil and biodegradable fluids
(HEES and HETG, see info-sheet 00.20)

Temperature range of fluids

0 °C ... +65 °C / +32 °F ... +149 °F
(also see viscosity range)

Ambient temperature range

0 °C ... +50 °C / +32 °F ... +122 °F

Viscosity range

Electro motor air cooled type of protection: IP 55	Continuous operation min.	Continuous operation max.	Short-term max.
3 ~ 400 V / 460 V	15 mm ² /s / 70 SUS	200 mm ² /s / 930 SUS	400 mm ² /s / 1860 SUS
1 ~ 230 V	15 mm ² /s / 70 SUS	200 mm ² /s / 930 SUS	400 mm ² /s / 1860 SUS
1 ~ 110 V	15 mm ² /s / 70 SUS	200 mm ² /s / 930 SUS	400 mm ² /s / 1860 SUS

Tank volume

Approx. 2.4 l / 0.6 gallons

Maximum suction height

1.5 m / 4.9 feet

Operating pressure

Max. 4 bar / 58 psi, pressure protection with pressure relief valve; cracking pressure see Selection Chart, column 11

Operating position

Vertical, motor at the bottom

Recommended tank capacities

FNA 008: 100 l ... 800 l / 25 ... 200 gallons
FNA 016: 400 l ... 1.500 l / 100 ... 400 gallons

Off-line filter units for tank capacities exceeding 1500 l / 400 gallons see catalog sheet 80.50

Filter fineness curves in Selection Chart, column 3

Dx Filtration ratio β as a function of particle size x obtained by the Multi-Pass Test according to ISO 16889

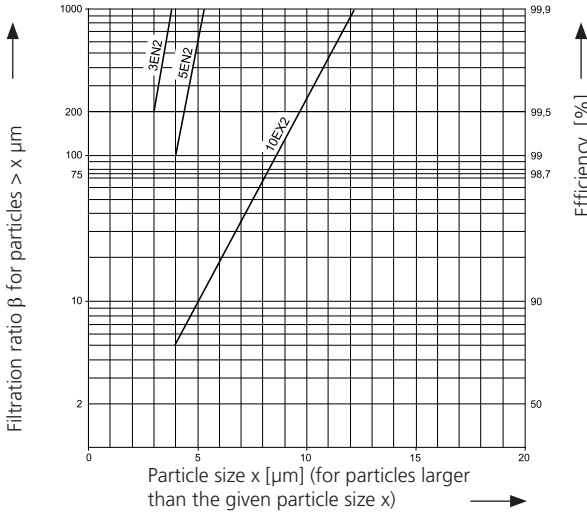

The abbreviations represent the following β -values resp. finenesses:

With EXAPOR[®]MAX 2 elements:

- 3EN2 = $\bar{\beta}_{3(c)} = 200$ EXAPOR[®]MAX 2
- 5EN2 = $\bar{\beta}_{5(c)} = 200$ EXAPOR[®]MAX 2
- 10EX2 = $\beta_{10(c)} = 200$ EXAPOR[®]MAX 2

For special applications, finenesses differing from these curves are also available by using special composed filter media.

Selection Chart, columns 1-10

Part No.	Nominal flow rate		Filter fineness see diagram Dx	Dirt-holding capacity	E-motor operating voltage	E-motor operating frequency (max.)	E-motor power (max.)	Engine speed at 50 Hz (max.)	Connection A Inlet	Connection B Outlet
	l/min	gpm								
1	2	3	4	5	6	7	8	9	10	
FNA 008-1763	10	2.6	3EN2	490	1 ~ 110 V	50 (60)	0.25 (0.3)*	1400 (1600)*	1 ¹ / ₁₆ -12 UN-2B	3 ⁴ / ₁₆ -16 UN-2B
FNA 008-1163	10	2.6	5EN2	460	1 ~ 110 V	50 (60)	0.25 (0.3)*	1400 (1600)*	1 ¹ / ₁₆ -12 UN-2B	3 ⁴ / ₁₆ -16 UN-2B
FNA 008-1573	8	2.1	3EN2	490	1 ~ 230 V	50 (60)	0.25 (0.3)*	1400 (1600)*	G ³ / ₄	G ¹ / ₂
FNA 008-1553	8*	2.1*	3EN2	490	3 ~ 400/460 V	50 (60)	0.25 (0.3)*	1400 (1600)*	G ³ / ₄	G ¹ / ₂
FNA 008-1753	8*	2.1*	3EN2	490	3 ~ 400/460 V	50 (60)	0.25 (0.3)*	1400 (1600)*	1 ¹ / ₁₆ -12 UN-2B	3 ⁴ / ₁₆ -16 UN-2B
FNA 008-1153	8*	2.1*	5EN2	460	3 ~ 400/460 V	50 (60)	0.25 (0.3)*	1400 (1600)*	G ³ / ₄	G ¹ / ₂
FNA 008-1556	8*	2.1*	10EX2	340	3 ~ 400/460 V	50 (60)	0.25 (0.3)*	1400 (1600)*	G ³ / ₄	G ¹ / ₂
FNA 016-1763	19	5.0	3EN2	280	1 ~ 110 V	50 (60)	0.45 (0.55)*	2800 (3300)*	1 ¹ / ₁₆ -12 UN-2B	3 ⁴ / ₁₆ -16 UN-2B
FNA 016-1163	19	5.0	5EN2	270	1 ~ 110 V	50 (60)	0.45 (0.55)*	2800 (3300)*	1 ¹ / ₁₆ -12 UN-2B	3 ⁴ / ₁₆ -16 UN-2B
FNA 016-1573	16	4.2	3EN2	280	1 ~ 230 V	50 (60)	0.45 (0.55)*	2800 (3300)*	G ³ / ₄	G ¹ / ₂
FNA 016-1173	16	4.2	5EN2	270	1 ~ 230 V	50 (60)	0.45 (0.55)*	2800 (3300)*	G ³ / ₄	G ¹ / ₂
FNA 016-1553	16*	4.2*	3EN2	280	3 ~ 400/460 V	50 (60)	0.45 (0.55)*	2800 (3300)*	G ³ / ₄	G ¹ / ₂
FNA 016-1753	16*	4.2*	3EN2	280	3 ~ 400/460 V	50 (60)	0.45 (0.55)*	2800 (3300)*	1 ¹ / ₁₆ -12 UN-2B	3 ⁴ / ₁₆ -16 UN-2B
FNA 016-1153	16*	4.2*	5EN2	270	3 ~ 400/460 V	50 (60)	0.45 (0.55)*	2800 (3300)*	G ³ / ₄	G ¹ / ₂
FNA 016-1773	16*	4.2*	5EN2	270	3 ~ 400/460 V	50 (60)	0.45 (0.55)*	2800 (3300)*	1 ¹ / ₁₆ -12 UN-2B	3 ⁴ / ₁₆ -16 UN-2B

* Indications at 50 Hz. At 60 Hz, the value increases by approx. 20%.

Selection Chart, columns 11-17

Part No.	Max. operating pressure (PRV)		Symbols hydraulic	Symbols electric	Measurements, Type No.	Replacement filter element Part No.	Clogging indicator	Remarks
	bar	psi						
	11		12	13	14	15	16	17
FNA 008-1763	4	58	1	3	3	V7.1220-113	optional	-
FNA 008-1163	4	58	1	3	3	V7.1220-13	optional	-
FNA 008-1573	4	58	1	3	4	V7.1220-113	optional	-
FNA 008-1553	4	58	1	1, 2	1	V7.1220-113	optional	-
FNA 008-1753	4	58	1	1, 2	2	V7.1220-113	optional	-
FNA 008-1153	4	58	1	1, 2	1	V7.1220-13	optional	-
FNA 008-1556	4	58	1	1, 2	1	V7.1220-06	optional	-
FNA 016-1763	4	58	1	3	2	V7.1220-113	optional	-
FNA 016-1163	4	58	1	3	2	V7.1220-13	optional	-
FNA 016-1573	4	58	1	3	1	V7.1220-113	optional	-
FNA 016-1173	4	58	1	3	1	V7.1220-13	optional	-
FNA 016-1553	4	58	1	1, 2	1	V7.1220-113	optional	-
FNA 016-1753	4	58	1	1, 2	2	V7.1220-113	optional	-
FNA 016-1153	4	58	1	1, 2	1	V7.1220-13	optional	-
FNA 016-1773	4	58	1	1, 2	2	V7.1220-13	optional	-

* Indications at 50 Hz. At 60 Hz, the value increases by approx. 20%.

As standard, all filter units are delivered with an unplugged clogging indicator connection M12 x 1.5.
For contamination monitoring, either manometers or electrical pressure switches can be used.

For appropriate clogging indicators see catalog sheet 60.20.

When using a manometer, version DG 200-16* has to be chosen.

Remarks:

- › In case of an increasing operating frequency, the pump delivery volume will increase as well.
- › The filter units listed in this chart are standard units. If modifications are required, e.g. with water-absorbing filter elements, hose extensions or mounting set as an accessory, we kindly ask for your request.
- › Clogging indicators are optionally available and will be supplied separately, if ordered.

* Manometer without throttle screw

Dimensions

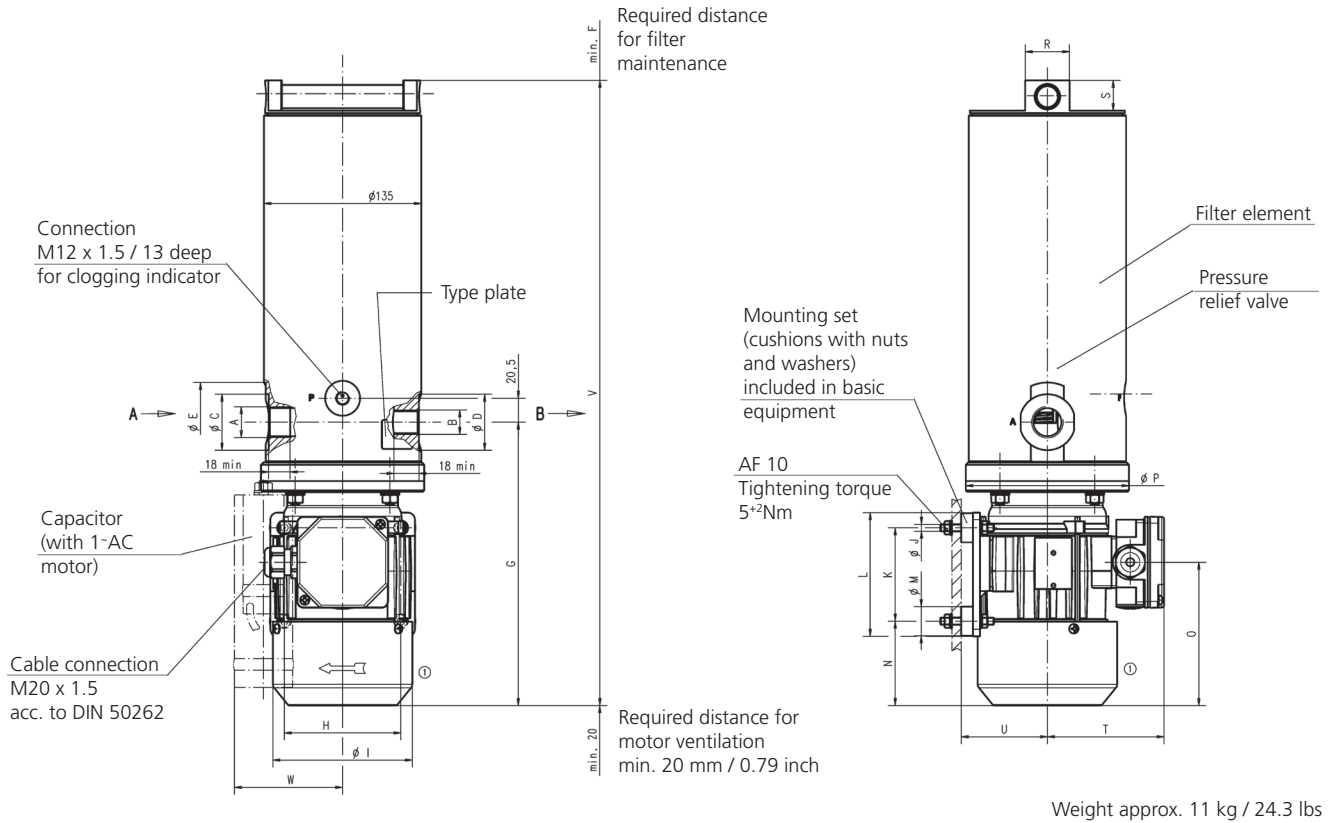

Measurements in mm

Type*	A	B	C	D	E	F	G	H	I	J	K	L	M
1	G ^{3/4}	G ^{1/2}	48	48	68	340	243	100	120	M6	80	106	25
2	G ^{3/4}	G ^{1/2}	48	48	68	340	243	100	120	M6	80	106	25
3	G ^{3/4}	G ^{1/2}	48	48	68	340	243	100	120	M6	80	106	25
4	1 ^{1/16} -12 UN-2B	3/4-16 UNF-2B	41	30	68	340	243	100	120	M6	80	106	25
5	1 ^{1/16} -12 UN-2B	3/4-16 UNF-2B	41	30	68	340	243	100	120	M6	80	106	25

Type*	N	O	P	R	S	T	U	V	W
1	72	123	140	38	26	101	74	535	-
2	72	123	140	38	26	101	74	535	100
3	72	123	140	38	26	122	74	535	100
4	72	123	140	38	26	101	74	535	100
5	72	123	140	38	26	101	74	535	100

*Type see Selection Chart, column 14

Measurements in inch

Type*	A	B	C	D	E	F	G	H	I	J	K	L	M
1	G ^{3/4}	G ^{1/2}	1.89	1.89	2.68	13.39	9.57	3.94	4.72	M6	3.15	4.17	0.98
2	G ^{3/4}	G ^{1/2}	1.89	1.89	2.68	13.39	9.57	3.94	4.72	M6	3.15	4.17	0.98
3	G ^{3/4}	G ^{1/2}	1.89	1.89	2.68	13.39	9.57	3.94	4.72	M6	3.15	4.17	0.98
4	1 ^{1/16} -12 UN-2B	3/4-16 UNF-2B	1.61	1.18	2.68	13.39	9.57	3.94	4.72	M6	3.15	4.17	0.98
5	1 ^{1/16} -12 UN-2B	3/4-16 UNF-2B	1.61	1.18	2.68	13.39	9.57	3.94	4.72	M6	3.15	4.17	0.98

Type*	N	O	P	R	S	T	U	V	W							
1	2.83	4.84	5.51	1.50	1.02	3.98	2.91	21.06	-							
2	2.83	4.84	5.51	1.50	1.02	3.98	2.91	21.06	3.94							
3	2.83	4.84	5.51	1.50	1.02	4.80	2.91	21.06	3.94							
4	2.83	4.84	5.51	1.50	1.02	3.98	2.91	21.06	3.94							
5	2.83	4.84	5.51	1.50	1.02	3.98	2.91	21.06	3.94							

*Type see Selection Chart, column 14

Symbols

Hydraulic:

1

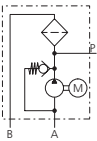

Electric:

1

Connections

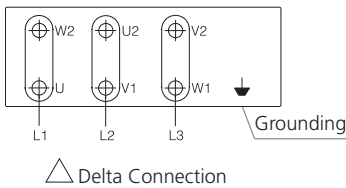

2

Connections

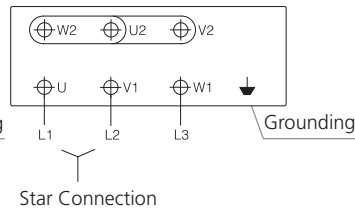

3

Connections

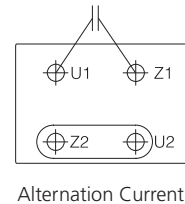

Quality Assurance

Quality management according to DIN EN ISO 9001

To ensure constant quality in production and operation, ARGO-HYTOS filter elements undergo strict controls and tests according to the following ISO standards:

- ISO 2941 Verification of collapse / burst pressure rating
- ISO 2942 Verification of fabrication integrity (Bubble Point Test)
- ISO 2943 Verification of material compatibility with fluids
- ISO 3968 Evaluation of pressure drop versus flow characteristics
- ISO 16889 Multi-Pass-Test (evaluation of filter fineness and dirt-holding capacity)
- ISO 23181 Determination of resistance to flow fatigue using high viscosity fluid

Various quality controls during the production process guarantee the leak-free function and solidity of our filters.

Illustrations may sometimes differ from the original. ARGO-HYTOS is not responsible for any unintentional mistake in this specification sheet.