

- Various designs regarding sizes and types
- Large selection of AC / DC voltages

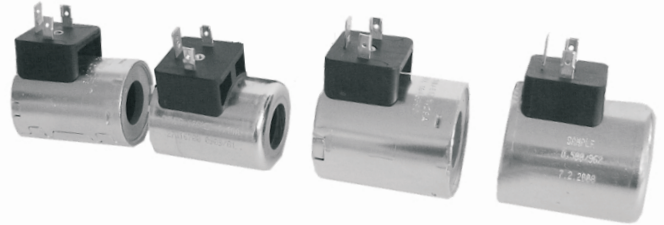

Ordering Code

C			-				-				/	M
Electromagnet coil												
Coil design (Size - according to the inner diameter)												
Ø 13,4 mm	14											
Ø 19,0 mm	19											
Ø 19,0 mm	20											
Ø 22,0 mm	22											
Ø 31,0 mm	31											
Coil housing design version												
Scrolled housing	A											
Drawn housing	B											
Long drawn housing	C											
Pressed part	D											
Rated voltage of solenoid (at the coil terminals)												
12 V DC	01200											
14 V DC	01400											
24 V DC	02400											
27 V DC	02700											
48 V DC	04800											
106 V DC	10600											
205 V DC	20500											
115 V 50 Hz	11550											
120 V 60 Hz	12060											
230 V 50 Hz	23050											
Type of solenoid coil see the page 18												
											E..	
Conductor design												
Non-braided												N
Braided												B
* For loose conductors only												
Special design												
Insulation design												
No designation											H	
Standard												
Version CSA												
Surface treatment												
A											ZnCr ₃	
B											Zn/Ni	
Detent type*												
N											Without detent	
F											With detent	
*C31 coils only												
Resistance												
...											Coil resistance (Ω)	
See the table of preferred coils												
Length of conductors												
300											Standard (300 mm)	
...											according to customer's requirements	
* For loose conductors only												

Coils C14		Type of solenoid coil					
Valve type	Voltage [V]	Current [A]	E1	E2	E3A	E4A	
RPEK1	01200	1,83	16210300 C14B-01200E1-6,55NA	24101600 C14B-01200E2-6,55NA	28822500 C14B-01200E3A-6,55NA	28822600 C14B-01200E4A-6,55NA	
	02400	0,92	16210400 C14B-02400E1-26,2NA	24101800 C14B-02400E2-26,2NA	28886400 C14B-02400E3A-6,55NA	28822400 C14B-02400E4A-6,55NA	
	20500**	0,08	16210500 C14B-20500E1-2476NA				

Notes: Only specified combinations are available in the table of preferred types. Other designs available at request.

* Coil versions 106 are suitable for the rectified voltage of 120V / 60Hz.

** Coil version 205 are suitable for the rectified voltage of 230V / 50Hz.

Coils C19		Type of solenoid coil										
Valve typel	Voltage	Current	E1	E2	E3	E4	E3A	E4A	E4A	E4A	E4A	
	[V]	[A]										
RPE3-04 ROE3-04 ROE3-06	01200	2,45	27316600 C19B-01200E1-4,90NA	27631400 C19B-01200E2-4,90NA	27930200 C19B-01200E3-4,90NA	27631600 C19B-01200E4-4,90NA	27449800 C19B-01200E3A-4,90NA	27631900 C19B-01200E4A-4,90NA				
	01400	1,66	27634100 C19B-01400E1-8,23NA	27634200 C19B-01400E2-8,23NA	27634300 C19B-01400E3-8,23NA	27634400 C19B-01400E4-8,23NA	27634500 C19B-01400E3A-8,23NA	27634600 C19B-01400E4A-8,23NA				
	02400	1,15	27316700 C19B-02400E1-20,8NA	27632400 C19B-02400E2-20,8NA	27930300 C19B-02400E3-20,8NA	27632200 C19B-02400E4-20,8NA	27449700 C19B-02400E3A-20,8NA	27633400 C19B-02400E4A-20,8NA				
	02700	0,89	27639100 C19B-02700E1-30,4NA	27639400 C19B-02700E2-30,4NA	27641600 C19B-02700E3-30,4NA	27641700 C19B-02700E4-30,4NA	27641800 C19B-02700E3A-30,4NA	27642100 C19B-02700E4A-30,4NA				
	04800	0,56	27825500 C19B-04800E1-86,9NA	----	----	----	----	----	----			
	10600*	0,22	27642600 C19B-10600E1-494NA	----	----	----	----	----	----			
	20500**	0,12	27382401 C19B-20500E1-1653NA	----	----	----	----	----	----			
	12060	0,22	----	----	----	----	----	----	----			
	23050	0,12	----	----	----	----	----	----	----			
	01200 CSA	2,41	24140700 C19A-01200E1-4,98NAH	----	----	----	----	----	----			
	02400 CSA	1,15	24140800 C19A-02400E1-21NAH	----	----	----	----	----	----			
	115500 CSA	0,24	----	----	----	----	----	----	----			
	23000 CSA	0,14	----	----	----	----	----	----	----			
	SD2E-A2/H SD2E-A3/H SD2E-A4/H SD3E-A2/H	01200	1,7	27666300 C19B-01200E1-7,1NA	27666700 C19B-01200E2-7,1NA	27667000 C19B-01200E3-7,1NA	27667100 C19B-01200E4-7,1NA					
01400		1,46	27823600 C19B-01400E1-9,6NA	----	----	----	----	----				
02400		0,83	27667700 C19B-02400E1-28,8NA	27667800 C19B-02400E2-28,8NA	27667900 C19B-02400E3-28,8NA	27668000 C19B-02400E4-28,8NA						
10600*		0,2	27668400 C19B-10600E1-527NA	----	----	----	----	----				
20500**		0,1	27668700 C19B-20500E1-2065NA	----	----	----	----	----				
12060		0,21	----	----	----	----	----	----				
23050		0,11	----	----	----	----	----	----				

Coils C19							
Valve type	Voltage [V]	Current [A]	Type of solenoid coil				
			E5	E8	E9	E12	E13
RPE3-04 ROE3-04 ROE3-06	01200	2,45	---	27632200 C19B-01200E8N300-4,90NA	27632100 C19B-01200E9N300-4,90NA	27351400 C19B-01200E12-4,90NA	27632000 C19B-01200E13-4,90NA
	01400	1,66	---	27634800 C19B-01400E8N300-8,23NA	27634900 C19B-01400E9N300-8,23NA	27635000 C19B-01400E12-8,23NA	27635100 C19B-01400E13-8,23NA
	02400	1,15	---	27633700 C19B-02400E8N300-20,8NA	27633600 C19B-02400E9N300-20,8NA	27330500 C19B-02400E12-20,8NA	27633500 C19B-02400E13-20,8NA
	04800	0,56	---	---	---	---	---
	10600*	0,22	---	---	---	---	---
	20500**	0,12	---	---	---	---	---
	12060	0,22	27642700 C19B-12060E5-494NA	---	---	---	---
	23050	0,12	27449900 C19B-23050E5-1653NA	---	---	---	---
	01200 CSA	2,41	---	---	---	---	---
	02400 CSA	1,15	---	---	---	---	---
SD2E-A2/H SD2E-A3/H SD2E-A4/H SD3E-A2/H	11550 CSA	0,24	24140900 C19A-11550E5-433NAH	---	---	---	---
	23050 CSA	0,12	24141000 C19A-23050E5-1653NAH	---	---	---	---
	01200	1,7	---	27667300 C19B-01200E8N300-7,1NA	27667400 C19B-01200E9N300-7,1NA	27351200 C19B-01200E12-7,1NA	27667500 C19B-01200E13-7,1NA
	01400	0,89	---	---	27866600 C19B-01400E9N300-9,6NA	---	---
	02400	0,83	---	27668200 C19B-02400E8N300-28,8NA	27668300 C19B-02400E9N300-28,8NA	27442600 C19B-02400E12-28,8NA	27667600 C19B-02400E13-28,8NA
	02700	0,74	---	---	27866400 C19B-012700E9N300-36,5NA	---	---
	10600*	0,2	---	---	---	---	---
	20500**	0,1	---	---	---	---	---
	12060	0,21	27668500 C19B-12060E5-527NA	---	---	---	---
	23050	0,11	27668600 C19B-23050E5-2065NA	---	---	---	---

Coils C19									
Valve type	Voltage [V]	Current [A]	Type of solenoid coil						
			E1	E2	E3	E4	E5	E8	E9
SD2E-B2/S SD2E-B3/S SD2E-B4/S SD3E-B2/S SD1E-A2	01200	2	27669700 C19B-01200E1-6NA	27669900 C19B-01200E2-6NA	27670000 C19B-01200E3-6NA	27670100 C19B-01200E4-6NA	---	27670300 C19B-01200E8N300-6NA	27670400 C19B-01200E9N300-6NA
	01400	1,66	27634100 C19B-01400E1-8,23NA	27634200 C19B-01400E2-8,23NA	27634300 C19B-01400E3-8,23NA	27634400 C19B-01400E4-8,23NA	---	27634800 C19B-01400E8-8,23NA	27634900 C19B-01400E9-8,23NA
	02400	0,93	27670600 C19B-02400E1-25,75NA	27670700 C19B-02400E2-25,75NA	27670800 C19B-02400E3-25,75NA	27670900 C19B-02400E4-25,75NA	---	27671000 C19B-02400E8N300-25,75NA	27671100 C19B-02400E9N300-25,75NA
	02700	0,89	27636100 C19B-02700E1-30,4NA	27639400 C19B-02700E2-30,4NA	27641600 C19B-02700E3-30,4NA	27641700 C19B-02700E4-30,4NA	---	27642200 C19B-02700E8N300-30,4NA	27642300 C19B-02700E9N300-30,4NA
	10600*	0,22	27642600 C19B-10600E1-494NA	---	---	---	---	---	---
	20500**	0,12	27382401 C19B-20500E1-1653NA	---	---	---	---	---	---
	12060	0,24	---	---	---	---	27642700 C19B-12060E5-494NA	---	---
	23050	0,13	---	---	---	---	27449900 C19B-23050E5-1653NA	---	---
	PRM2-04 with electronic	01200	max.1,7	16186100 C19A-01200E1-4,98NA/M	---	---	---	---	---
	PRM2-04 without el.	01200	max.1,7	27821900 C19B-01200E1-4,68NA/M	---	---	---	---	---
PRM7-04 with electronic	02400	max.0,8	16186200 C19A-02400E1-21NA/M	---	---	---	---	---	
PRM7-04 without el.	02400	max.0,8	27824200 C19B-02400E1-20,8NA/M	---	---	---	---	---	
PVRM1-063/S	01200	max.1	---	---	---	23881200 C19B-01200E4-7,1NA/M	---	---	
Coils C20									
Valve type	Voltage [V]	Current [A]	Type of solenoid coil						
			E2	E4	E13				
SR1P2-A2 SR4P2-B2 SP4P2-B3	01200	1	28145600 C19B-01200E2-6,5NA	28145800 C19B-01200E4-6,5NA	---	---	---	29867600 C19B-01200E13-6,5NA	
	02400	0,75	28145100 C19B-02400E2-20,1NA	28145300 C19B-02400E4-20,1NA	---	---	---	29868600 C19B-02400E13-20,8NA	
RPEW4-06	12060	0,27	16205300 C20D-12060EW5-27,6N/M	---	---	---	---	---	

Notes: Only specified combinations are available in the table of preferred types. Other designs available at request.
 * Coil versions 106 are suitable for the rectified voltage of 120V / 60Hz.
 ** Coil version 205 are suitable for the rectified voltage of 230V /50Hz.

Coils C22							
Valve type	Voltage [V]	Current [A]	Type of solenoid coil				
			E1	E2	E3A	E4	E5
RPE3-06	01200	2,72	16211400 C22B-01200E1-4,41NA	24156100 C22B-01200E2-4,41NA	24159600 C22B-01200E3A-4,41NA	24159700 C22B-01200E4A-4,41NA	---
	01400	2,14	24158200 C22B-01400E1-6,55NA	24930900 C22B-01400E2-6,55NA	27662100 C22B-01400E3A-6,55NA	27662200 C22B-01400E4A-6,55NA	---
	02400	1,29	16211600 C22B-02400E1-18,6NA	24157400 C22B-02400E2-18,6NA	24159800 C22B-02400E3A-18,6NA	24159900 C22B-02400E4A-18,6NA	---
	02700	1,07	16211700 C22B-02700E1-25,3NA	24157600 C22B-02700E2-25,3NA	19744600 C22B-02700E3A-25,3NA	19744500 C22B-02700E4A-25,3NA	---
	10600*	0,26	24157800 C22B-10600E1-400NA	---	---	---	---
	20500**	0,15	16211500 C22B-20500E1-1400NA	---	---	---	---
	11550	0,3	---	---	---	---	27510100 C22B-11550E5-344NA
	12060	0,26	---	---	---	---	---
	23050	0,15	---	---	---	---	18849000 C22B-23050E5-1400NA
	01200 CSA	2,72	24154300 C22A-01200E1-4,41NAH	---	---	---	---
02400 CSA	1,29	24154400 C22A-02400E1-18,6NAH	---	---	---	---	
23050 CSA	0,15	---	---	---	---	24154600 C22A-23050E5-1393NAH	
SD2E-B2/H SD2E-B3/H SD2E-B4/H SD3E-B2/H	01200	1,83	27222400 C22B-01200E1-6,55NA	27222500 C22B-01200E2-6,55NA	27222600 C22B-01200E3A-6,55NA	27222700 C22B-01200E4A-6,55NA	---
	02400	0,95	27222800 C22B-02400E1-25,3NA	27222900 C22B-02400E2-25,3NA	27223000 C22B-02400E3A-25,3NA	27223100 C22B-02400E4A-25,3NA	---
	10600*	0,19	27223200 C22B-10600E1-545NA	---	---	---	---
	20500**	0,09	24160100 C22B-20500E1-2353NA	---	---	---	---
	12060	0,19	---	---	---	---	20004100 C22B-12060E5-545NA
	23050	0,09	---	---	---	---	20004200 C22B-23050E5-2353NA
	---	---	---	---	---	---	---

Notes: Only specified combinations are available in the table of preferred types. Other designs available at request.

* Coil versions 106 are suitable for the rectified voltage of 120V / 60Hz.

** Coil version 205 are suitable for the rectified voltage of 230V /50Hz.

Coils C22

Valve type	Type of solenoid coil					
	Voltage [V]	Current [A]	E8	E9	E12	E13
RPE3-06	01200	2,72	19961300 C22B-01200E8N300-4,41NA	19961400 C22B-01200E9N300-4,41NA	24930801 C22B-01200E12-4,41NA	19695100 C22B-01200E13-4,41NA
	01400	2,14	27662500 C22B-01400E8N300-6,55NA	27662900 C22B-01400E9N300-6,55NA	27663000 C22B-01400E12-6,55NA	27663100 C22B-01400E13-6,55NA
	02400	1,29	19961000 C22B-02400E8N300-18,6NA	19961700 C22B-02400E9N300-18,6NA	19695900 C22B-02400E12-18,6NA	19696000 C22B-02400E13-18,6NA
	02700	1,07	27662700 C22B-02700E8N300-25,3NA	27662800 C22B-02700E9N300-25,3NA	27663200 C22B-02700E12-25,3NA	27663300 C22B-02700E13-25,3NA
	01200	1,83	19963200 C22B-01200E8N300-6,55NA	19963400 C22B-01200E9N300-6,55NA	18815601 C22B-01200E12-6,55NA	19908000 C22B-01200E13-6,55NA
	02400	0,95	19963500 C22B-02400E8N300-25,3NA	18069900 C22B-02400E9N300-25,3NA	19909101 C22B-02400E12-25,3NA	19909200 C22B-02400E13-25,3NA
SD2E-B2/H SD2E-B3/H SD2E-B4/H SD3E-B2/H						

Notes: Only specified combinations are available in the table of preferred types. Other designs available at request.

* Coil versions 106 are suitable for the rectified voltage of 120V / 60Hz.

** Coil version 205 are suitable for the rectified voltage of 230V / 50Hz.

Coils C22

Valve type	Voltage [V]	Current [A]	Type of solenoid coil			
			E1	E3A	EW1	EW2
RPEA3-06	02400	0,33	---	---	24014000 C22C-02400EW1-72NA/M	---
	01200	2,72	---	---	16205100 C22C-01200EW1-4,54NA/M	16205400 C22C-01200EW2-4,54NA/M
	02400	1,26	---	---	16205000 C22C-02400EW1-18,2NA/M	16205500 C22C-02400EW2-18,2NA/M
RPEW4-06	10600	0,27	---	---	24154700 C22C-01200EW1-4,54NAH/M	---
	01200 CSA	2,64	---	---	24154900 C22C-02400EW1-18,2NAH/M	---
	01200	max 2.5	16186400 C22A-01200E1-2,33NA	---	---	---
PRM2-06	01200	max 1.6	16187500** C22A-01200E1-5,15NA	---	---	---
	02400	max 1	16186800 C22A-02400E1-13,4NA	---	---	---
	01200	max 2.5	16186400 C22A-01200E1-2,33NA	---	---	---
PRM7-06	02400	max 1	16186800 C22A-02400E1-13,4NA	---	---	---
	01200	max 1.5	24157900 C22B-01200E3A-5NA	---	---	---

Notes: Only specified combinations are available in the table of preferred types. Other designs available at request.

* Coil versions 106 are suitable for the rectified voltage of 120V / 60Hz.

** Coil version 205 are suitable for the rectified voltage of 230V / 50Hz.

*** Input signal level for 12V-electronics.

Coils C31										
Valve type	Type of solenoid coil									
	Voltage [V]	Current [A]	E1	E2	E3	E4	E5	E8	E9	EW1
RPE4-10	01200	3,17	16195700 C31A-01200E1-3,78FA	27660800 C31A-01200E2-3,78FA	16197000 C31A-01200E3-3,78FA	16196900 C31A-01200E4-3,78FA	---	16198800 C31A-01200E8N300-3,78FA	23910200 C31A-01200E9N300-3,78FA	---
	01400	2,98	16195900 C31A-01400E1-4,73FA	27660900 C31A-01400E2-4,73FA	27661100 C31A-01400E3-4,73FA	27661200 C31A-01400E4-4,73FA	---	27661500 C31A-01400E8N300-4,73FA	27661600 C31A-01400E9N300-4,73FA	---
	02400	1,73	16196100 C31A-02400E1-13,9FA	23896000 C31A-02400E2-13,9FA	16197200 C31A-02400E3-13,9FA	16197100 C31A-02400E4-13,9FA	---	23904500 C31A-02400E8N300-13,9FA	23910300 C31A-02400E9N300-13,9FA	---
	02700	1,52	16196300 C31A-02700E1-17,8FA	27661000 C31A-02700E2-17,8FA	27661300 C31A-02700E3-17,8FA	27661400 C31A-02700E4-17,8FA	---	27661700 C31A-02700E8N300-17,8FA	27662000 C31A-02700E9N300-17,8FA	---
	10600*	0,38	23898000 C31A-10600E1-276FA	---	---	---	---	---	---	---
	20500**	0,2	16196700 C31A-20500E1-1027FA	---	---	---	---	---	---	---
	12060	0,38	---	---	---	---	17366300 C31A-12060E5-276FA	---	---	---
	23050	0,2	---	---	---	---	16195100 C31A-23050E5-1027FA	---	---	---
	01200	3,17	---	---	---	---	---	---	---	24172000 C31A-01200EW1-3,78FA/M
	02400	1,73	---	---	---	---	---	---	---	24172200 C31A-02400EW1-13,9FA/M
16000	0,38	---	---	---	---	---	---	---	24172400 C31A-10600EW1-276FA/M	
01200	max,1,9	16195800 C31A-01200E1-4,73FA	---	---	---	---	---	---	---	---
02400	max,1,1	16196200 C31A-02400E1-13,9FA/M	---	---	---	---	---	---	---	---

Notes: Only specified combinations are available in the table of preferred types. Other designs available at request.
 * Coil versions 106 are suitable for the rectified voltage of 120V / 60Hz.
 ** Coil version 205 are suitable for the rectified voltage of 230V /50Hz.

Rectifier Connection in the Coil with "E5" Connector

In-built bridge rectifier for the maximum output voltage $253 V_{eff}$
 Voltage frequency 50 – 60 Hz. Varistor for $275 V_{eff}$

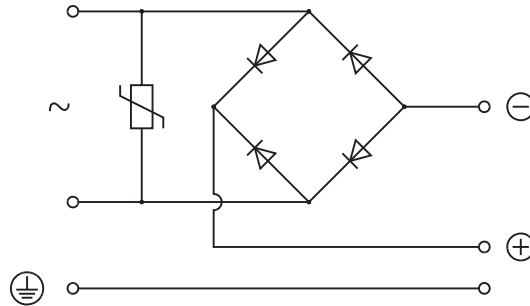

Dimensions of Coils C14

Dimensions in millimeters (inches)

Design version - B

Connector design

E1 (Connector EN 175301-803-A)

Protection degree IP65

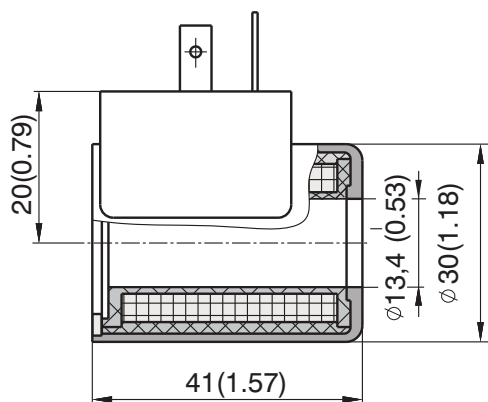

Connector design

E3A (Connector AMP-Junior-Timer - (2-pins; male)

E4A (E3A with quenching diode)

Protection degree IP67

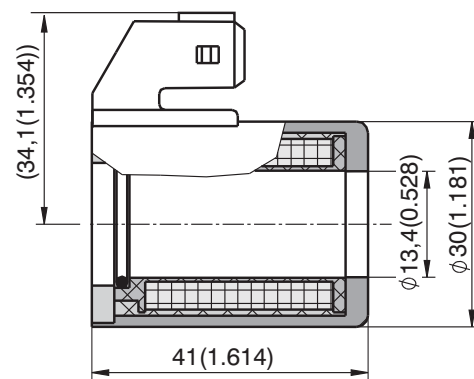

Dimensions of Coils C19

Dimensions in millimeters (inches)

Design version - A

Connector design

E1 (Connector EN 175301-803-A)

E2 (E1 with quenching diode)

Protection degree IP65

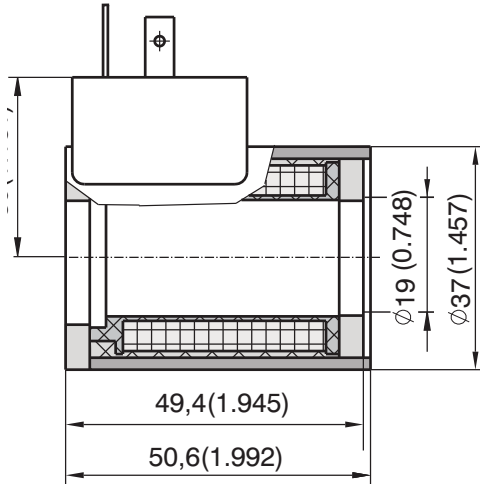

Design version - B

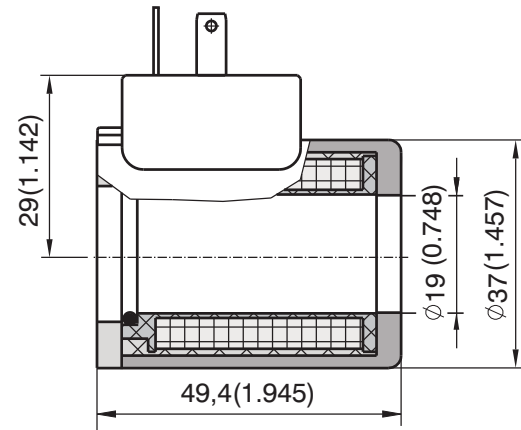

Design version - B

Connector design

E3 (Connector AMP-Junior-Timer - (2-pins; male)

E4 (E3 with quenching diode)

Protection degree IP67

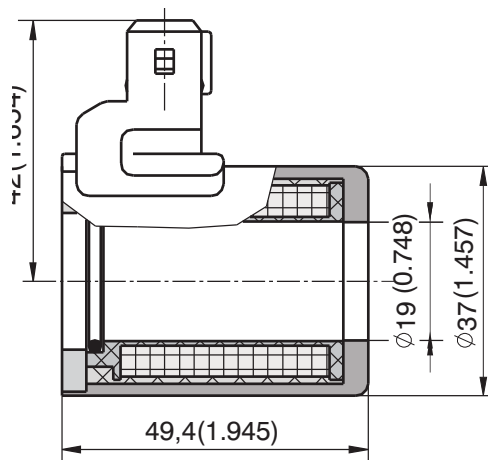

Design version - B

Connector design

E3A (Connector AMP-Junior-Timer - (2-pins; male)

E4A (E3A with quenching diode)

Protection degree IP67

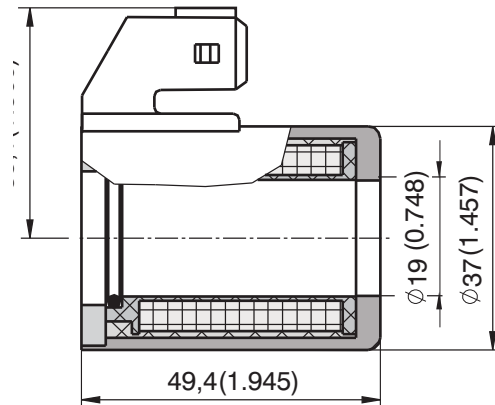

Dimensions of Coils C19

Dimensions in millimeters (inches)

Design version - A

Connector design

E5 (Connector EN 175301-803-A with integrated rectifier)

Protection degree IP67

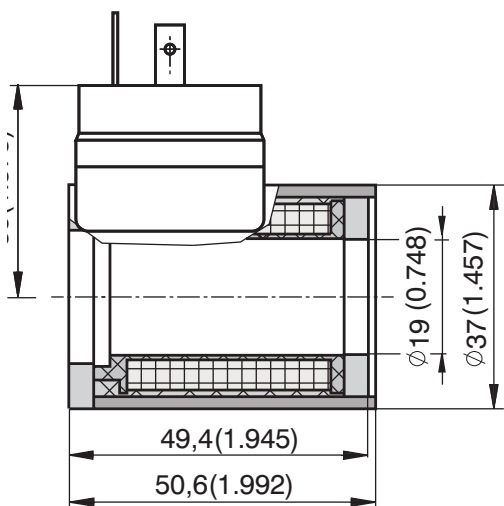

Design version - B

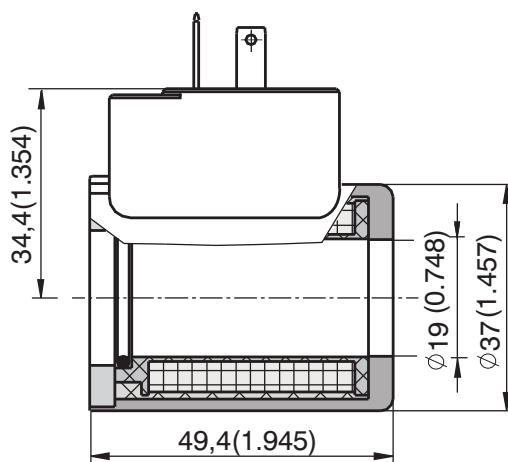

Design version - B

Connector design

E8 (Loose conductors (two insulated cables))

E9 (E8 with quenching diode)

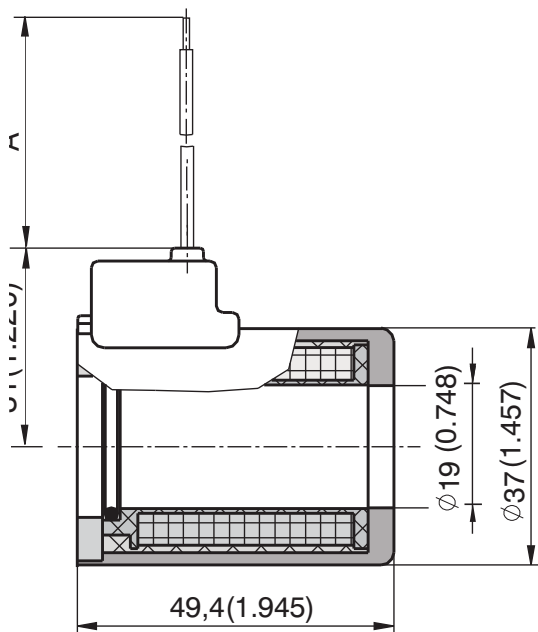

Design version - B

Connector design

E12 (Deutsch DT04-2P)

E13 (E12 with quenching diode)

Protection degree IP67

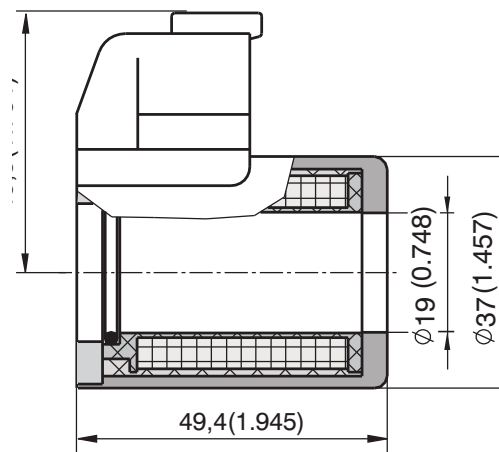

Note:

A = Standard 300 mm, other sizes on demand

Dimensions of Coils C20

Dimensions in millimeters (inches)

Design version - D

Connector design

EW5 - (Wirebox)

Protection degree IP65

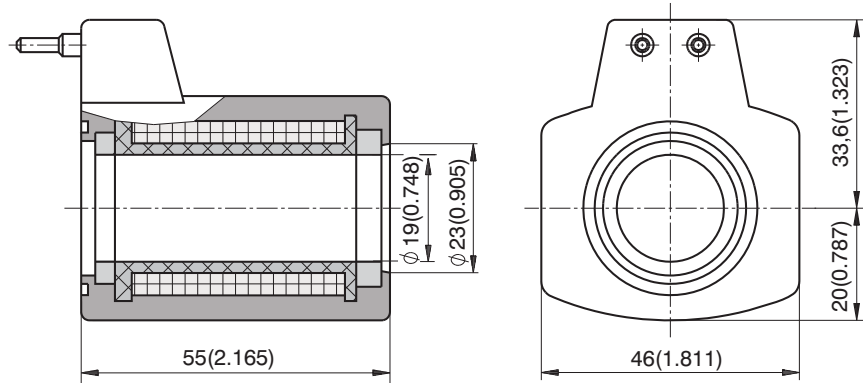

Dimensions of Coils C22

Dimensions in millimeters (inches)

Design version - A

Design version - B

Connector design

E1 (E1 = Connector EN 175301-803-A)

E2 (E2 = E1 with quenching diode)

Protection degree IP65

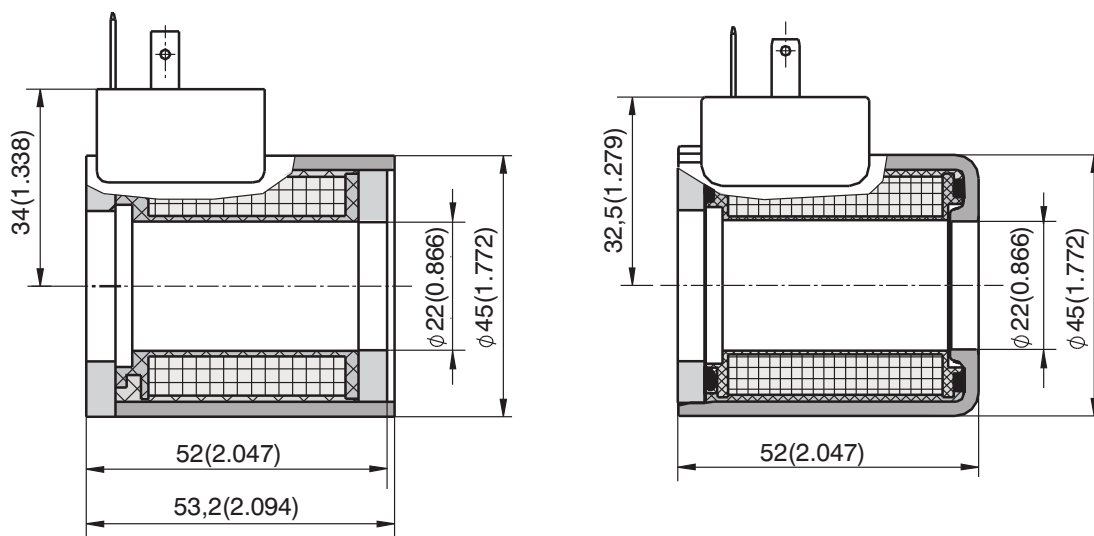

Dimensions of Coils C22

Dimensions in millimeters (inches)

Design version - B

Connector design

E3A (Axial connector AMP Junior Timer (2 pins; male))

E4A (E3A with quenching diode)

Protection degree IP67

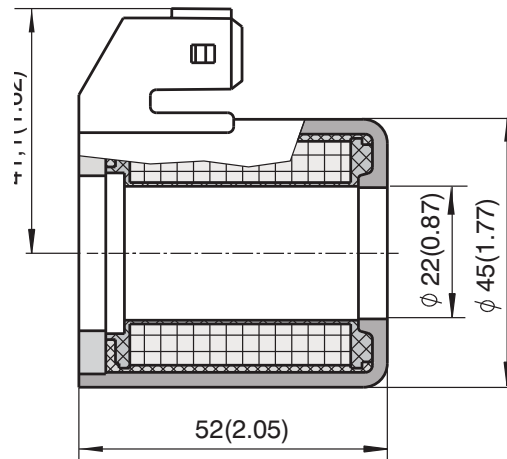

Design version - A

Connector design

E5 (Connector EN 175301-803-A with integrated rectifier)

Protection degree IP65

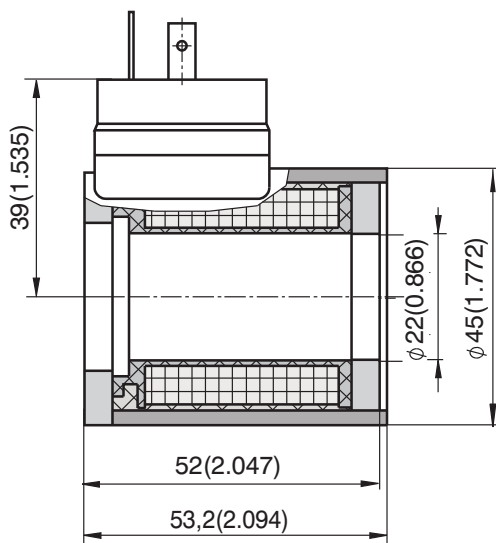

Design version - B

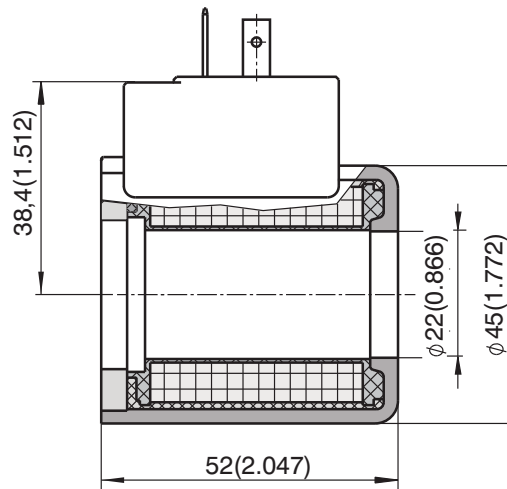

Dimensions of Coils C22

Dimensions in millimeters (inches)

Design version - B

Connector design

E8 (Loose conductors (two insulated cables))

E9 (E8 with quenching diode)

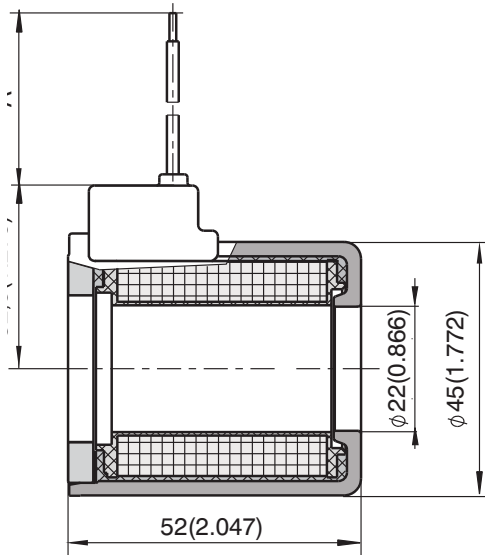

Design version - B

Connector design

E12 (Deutsch DT04-2P)

E13 (E12 with quenching diode)

Protection degree IP67

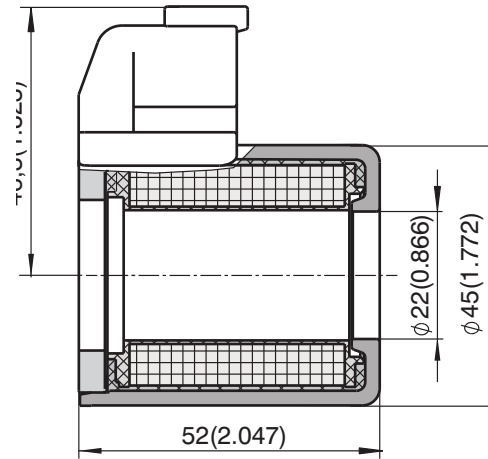

Note:

A = Standard 300 mm, other sizes on demand

Design version - C

Connector design

EW1 - (wirebox)

EW2 - (E3 with quenching diode)

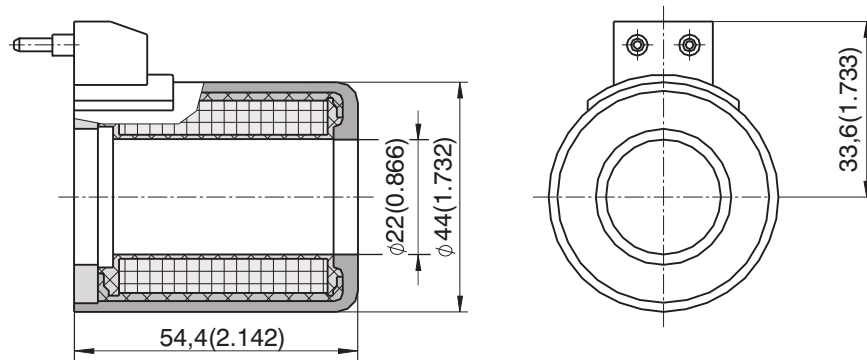

Dimensions of Coils C31

Dimensions in millimeters (inches)

Design version - A

Connector design

- E1 (Connector EN 175301-803-A)
- E2 (E1 with quenching diode)

Protection degree IP65

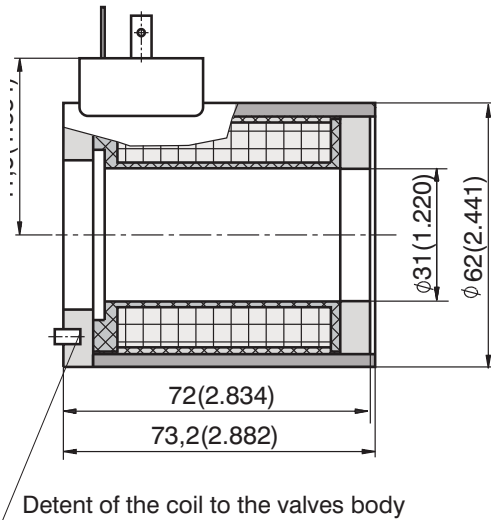

Design version - A

Connector design

- E3 (Connector AMP-Junior-Timer - (2-pins; male)
- E4 (E3 with quenching diode)

Protection degree IP67

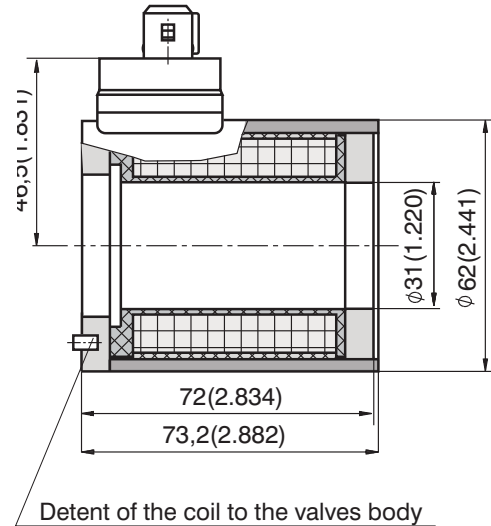

Design version - A

Connector design

- E5 (Connector EN 175301-803-A with integrated rectifier)

Protection degree IP65

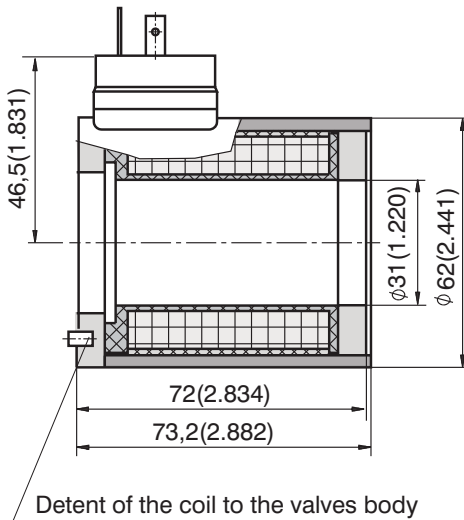

Design version - A

Connector design

- E8 (Loose conductors (two insulated cables))
- E9 (E8 with quenching diode)

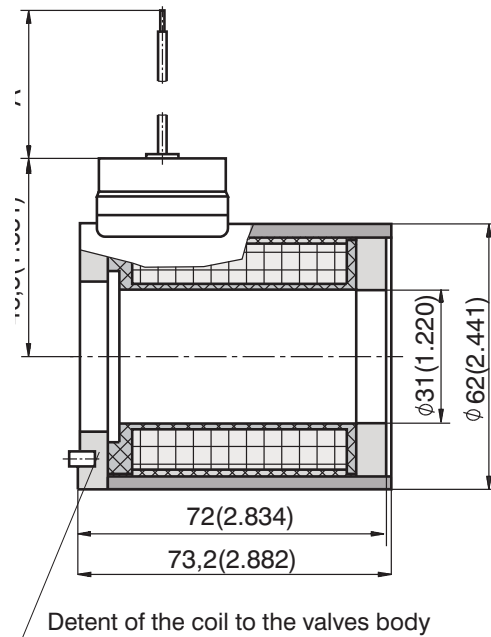

Note:

A = Standard 300 mm, other sizes on demand

Dimension of Coils C31

Dimensions in millimeters (inches)

Design version - A

Connector design

EW1 - (Wirebox)

Protection degree IP65

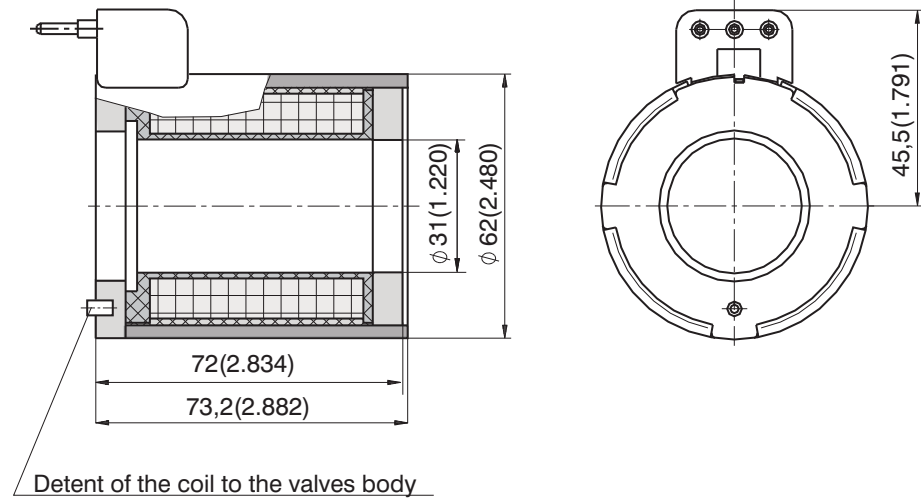

Identification and Survey of the Offered Connectors

Connector	Connector description
E1	Connector EN 175301-803-A
E2	Connector E1 with quenching diode
E3	Connector AMP Junior Timer (2 pins; male)
E4	Connector E3 with quenching diode
E3A	Axial connector AMP Junior Timer (2 pins; male)
E4A	Connector E3A with quenching diode
E5	Connector EN 175301-803-A with integrated rectifier
E51	Connector EN 175301-803-A with integrated recrifier and fast deconnection
E6	Connector Kostal
E7	Connector E6 with quenching diode
E8	Loose conductors (two insulated cables)
E9	E8 with quenching diode
E10	Loose conductors and Deutsch connector DT04-2P (2 pins; male)
E11	E10 witch quenching diode
E12	Connector Deutsch DT04-2P (2 pins; male)
E13	Connector E12 with quenching diode
E14	Connector Spade
E15	Connector E14 with quenching diode
E16	Loose conductors and Metri-Pack connector Series 150 (2 pins; male)
E17	Connector E16 with quenching diode
E18	Loose conductors and Weather-Pack onnector (2 pins; male)
E19	Connector E18 with quenching diode
E20	Loose conductors and Weather-Pack connector (2 pins; male)
E21	Connector E20 with quenching diode
E22	Loose conductors and Econoseal connector (2 pins; male)
E23	Connector E22 with quenching diode
E24	Loose conductors and AMP Junior Timer (2 pins; male)
E25	Connector E24 with quenching diode
EW1	Konektor for Wirebox
EW2	Connector EW1 with quenching diode
EW5	Connector for Wirebox (AC coil)

Survey of Available Connectors and Coils

Connector								
	C14B	C19A	C19B	C20D	C22A	C22B	C22C	C31A
E1	X	X	X		X	X		X
E2	X	X	X		X	X		X
E3			X					X
E3A			X			X		
E4			X					X
E4A			X			X		
E5			X			X		X
E51			X			X		X
E6								
E7								
E8			X			X		X
E9			X			X		X
E10			X			X		X
E11			X			X		X
E12			X			X		
E13			X			X		
E14								
E15								
E16			X			X		X
E17			X			X		X
E18			X			X		X
E19			X			X		X
E20			X			X		X
E21			X			X		X
E22			X			X		X
E23			X			X		X
E24			X			X		X
E25			X			X		X
EW1							X	X
EW2							X	X
EW5				X				

All versions are available with loose conductors (E8 a E9) eventually with loose conductors + connector.
(E10; E11; E16; E17; E18; E19; E20; E21; E23; E24 a E25) conductors can be protected with braiding (B).

Caution!

- The packaging foil can be recycled.
- All stated data serve for the product description only and in no case should be understood as features guaranteed in terms of law.

ARGO-HYTOS s.r.o. CZ - 543 15 Vrchlaví
tel.: +420-499-403 111
e-mail: info.cz@argo-hytos.com
www.argo-hytos.com