

- The valve prevents runaway in the event of a negative load
- Load-holding without leakage
- Pressure relief function protecting the actuator against overload and pressure peaks
- When installed into the actuator the valve can be used as a hose burst valve
- When used as pressure relief the check valve will act as an anti-cavitation valve
- The valve should be mounted as close as possible to the actuator
- Fits the same cavity as the Q3 check valve

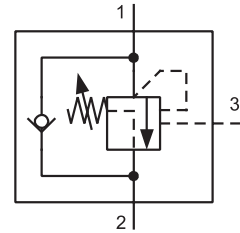

Functional Description

The valve consists of a seat by-pass, relief valve fitted with an auxiliary control with a differential piston and by-pass single-way valve serving for reverse direction of flow. The liquid is flowing through the single-way valve from the channel (2) to the channel (1) with a small pressure drop. In the opposite direction the single-way valve on the rear side of which a gate valve seat is fitted is pressed through the action of a spring and the load pressure against the spring-loaded valve gate valve. In this way the valve is nearly closed hermetically. If the pressure in the channel (1) exceeds a set up value of the spring force the gate valve is pressed out of the seat and the overpressure in that case is relieved into channel (2). For ensuring the function of holding the load the spring force should be set up to a value by 30 % higher when compared to an expected pressure exerted by the load.

If the load has to be moved it is possible to ensure it with the help of so called auxiliary control from the channel (3) by introducing already certain control pressure.

The control pressure is calculated in the following way:

$$\text{Control pressure} = \frac{\text{set up pressure} - \text{load pressure}}{\text{ratio of control}}$$

The ratio of control designates a ratio of surfaces of the differential slide valve cross-section area and its seat. Therefore, the necessary control pressure for opening the valve does not correspond to the difference between the set up pressure and load pressure however; it corresponds to the ratio of this difference and the control ratio. In the formula as mentioned above it is necessary to take into consideration that in differential cylinders it is necessary to add to the control ratio also the appropriate ratio of piston surfaces in the direction of movement.

As soon as the control pressure attains a necessary value the differential gate valve is moved out from the seat and then the way from the channel (1) to the channel (2) is released. If now the load tries to accelerate and be fast as for the oil supply the supply pressure decreases, therefore, also the control pressure in the channel (3) is decreased. The spring force tries to shut off the valve again, therefore, in consequence of which the flow from the consumer decreases and the inlet pressure to the consumer increases again. In this way it is ensured a constant inlet pressure by means of which the movement of the load can be controlled.

As for appropriate basic surface finish the external parts are zinc coated.

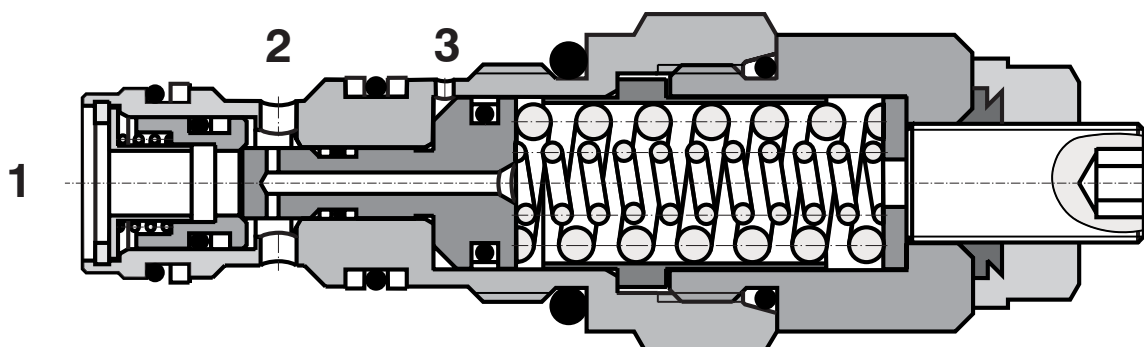

Ordering Code

SO5A-Q3/I



Overcentre Valve

NBR

No designation

Pilot ratio

For applications with varying load	2,5:1	2
Standard	5:1	5
For applications with a constant load	10:1	10

Technical Data

Cavity		M20 x 1,5
Maximum flow	L/min	30
Max. pressure	bar	270
Max. input pressure	bar	350
Pressure drops	bar	see Δp - Q characteristics
Hydraulic fluid		Hydraulic oil (HL, HLP) according to DIN 51524
Fluid temperature range	°C	-20 ... +90
Viscosity	mm ² /s	20 ... 400
Maximum degree of fluid contamination		according to ISO 4406 (1999), Class 21/18/15
Weight	kg	0,15
Maximum valve tightening torque in valve body or in control block	Nm	45 ⁺²
Mounting position		any

Δp -Q Characteristics

Measured at $\nu = 40 \text{ mm}^2/\text{s}$

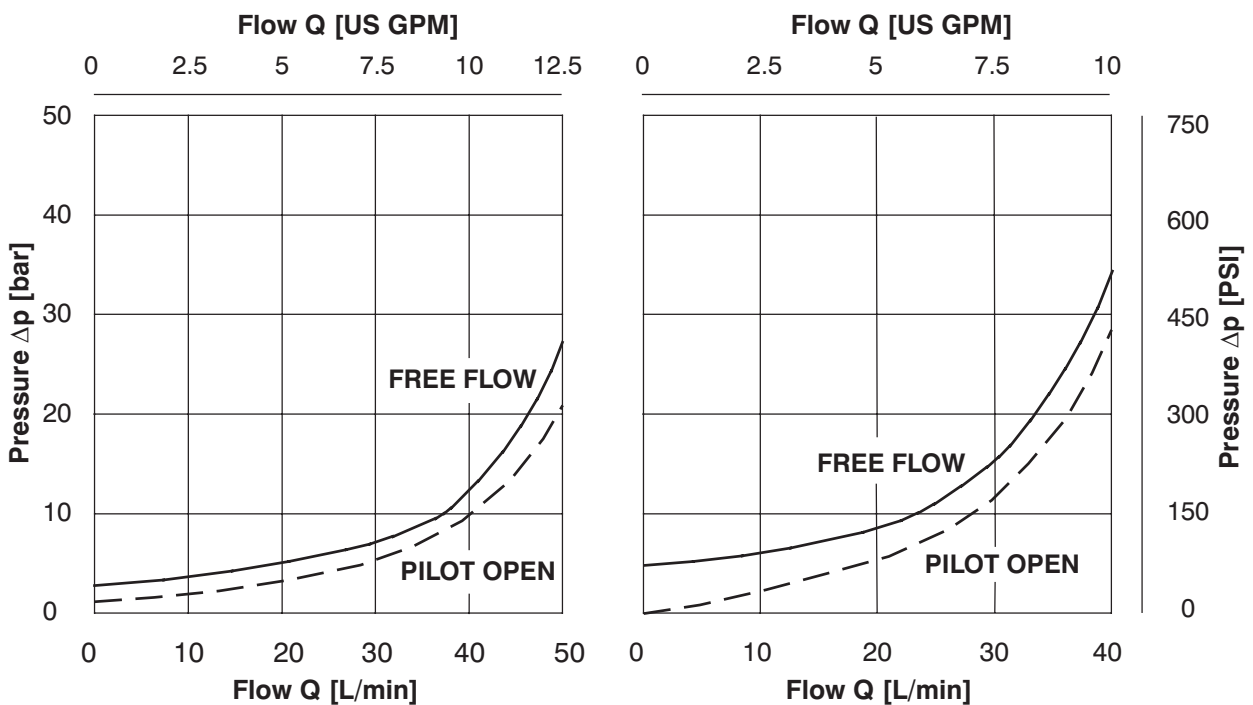

Valve Bodies

Measurements in millimeters

ISO A

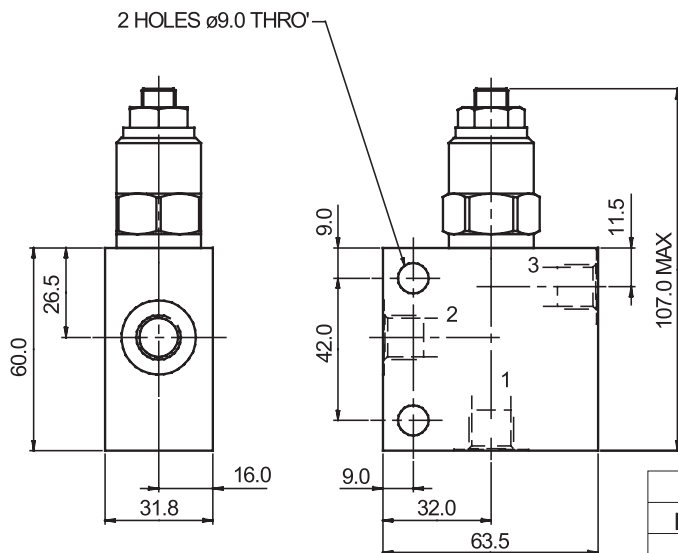
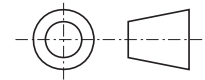

Body without valve			
Material	Ports	Port size	Type code
Aluminium	1, 2	G3/8	SB-Q3-0103AL
	3	G1/4	
	1, 2	SAE 8, 3/4-16	SB-Q3-0104AL
	3	SAE 6, 9/16-18	
Steel	1, 2	G3/8	SB-Q3-0103ST
	3	G1/4	
	1, 2	SAE 8, 3/4-16	SB-Q3-0104ST
	3	SAE 6, 9/16-18	

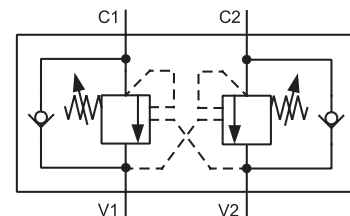
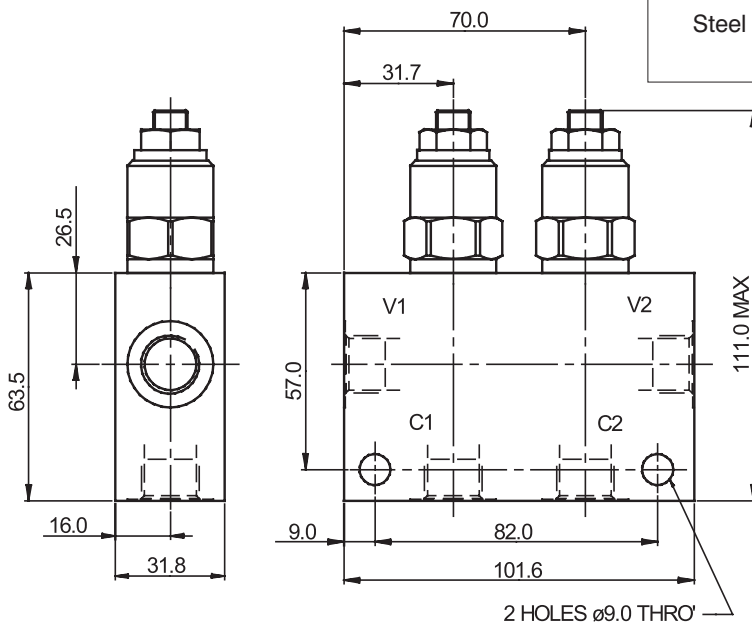

Dual body without valve			
Material	Ports	Port size	Type code
Aluminium	C1, C2, V1, V2	G3/8	SB-Q4-0203AL
	C1, C2, V1, V2	SAE 8, 3/4-16	SB-Q4-0204AL
Steel	C1, C2, V1, V2	G3/8	SB-Q4-0203ST
	C1, C2, V1, V2	SAE 8, 3/4-16	SB-Q4-0204ST

The use of aluminium bodies is limited to a maximum operating pressure of 210 bar.

Spare Parts

Seal kits on request.

Caution!

- The packing foil is recyclable.
- The technical information regarding the product presented in this catalogue is for descriptive purposes only. It should not be construed in any case as a guaranteed representation of the product properties in the sense of the law.

ARGO-HYTOS s.r.o. CZ - 543 15 Vrchlaví
 Tel.: +420-499-403111, Fax: +420-499-403421
 E-mail: sales.cz@argo-hytos.com
 www.argo-hytos.com