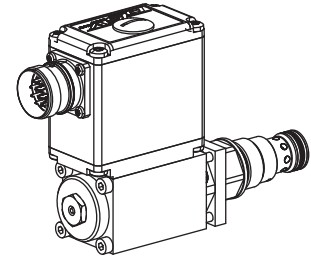

**Proportional pressure relief valve
 Screw-in cartridge**

- Integrated electronics
- Pilot operated
- $Q_{max} = 100$ l/min
- $p_{max} = 400$ bar
- $p_{Nmax} = 350$ bar

M22x1,5
 ISO 7789

DESCRIPTION

Pilot operated proportional pressure relief valve with integrated electronics as a screw-in cartridge. Thread M22x1,5 for cavity according to ISO 7789. These plug & play valves are factory set and adjusted. High valve-to-valve reproducibility. Housing for electronics with protection class IP67 for harsh environment. 7 standard pressure levels are available. Adjustment by a Wandfluh proportional solenoid (VDE standard 0580). The cartridge and the solenoid made of steel are zinc coated and therefore rustprotected.

FUNCTION

When the operating pressure set by the proportional solenoid is reached, the main spool opens and connects the protected line with the return line to the tank. The back pressure in T (2) influences the pressure in P (1). The control connection is provided by an analog interface or a fieldbus interface (CANopen or Profibus DP). Parameter setting and diagnosis with the free-of-charge software «PASO» or via fieldbus interface. After taking off the cover of the electronics housing, the serial interface to adjust the settings is accessible. The menu controlled Windows program «PASO» allows easy adjustment of all variable settings. Data are stored in a non-volatile memory. Even after an electric power failure settings can easily be reproduced and transmitted.

APPLICATION

Proportional pressure relief valves with integrated electronics are well suited for demanding applications, in which the pressure frequently has to be changed. They are implemented in systems calling for good valve-to-valve reproducibility, easy installation, comfortable operation and high precision in industrial hydraulics as well as in mobile hydraulics. The proportional pressure relief cartridge is very suitable for mounting in control blocks, flange bodies and sandwich plates of the size NG4-Mini NG6 and NG10. (Please note the separate data sheets in register 2.3). Cavity tools are available for machining the cavities in steel and aluminium (hire or purchase). Please refer to the data sheets in register 2.13.

CONTENT

GENERAL SPECIFICATIONS.....	1
SYMBOL.....	1
HYDRAULIC SPECIFICATIONS	2
ELECTRICAL SPECIFICATIONS.....	2
START-UP	2
CONNECTOR WIRING DIAGRAM	2
CHARACTERISTICS.....	3
DIMENSIONS/ SECTIONAL DRAWINGS.....	4
PARTS LIST	4
ACCESSORIES (not included).....	4

TYPE CODE

	B V V PM22 - <input type="text"/> - <input type="text"/> <input type="text"/> # <input type="text"/>																
Pressure relief valve																	
Pilot operated																	
Proportional valve with integrated electronics																	
Screw-in cartridge M22x1,5																	
Standard nominal pressure ranges:	<table border="0" style="display: inline-table; vertical-align: top;"> <tr> <td>$p_N = 20$ bar</td> <td><input type="text" value="20"/></td> <td>$p_N = 200$ bar</td> <td><input type="text" value="200"/></td> </tr> <tr> <td>$p_N = 63$ bar</td> <td><input type="text" value="63"/></td> <td>$p_N = 250$ bar</td> <td><input type="text" value="250"/></td> </tr> <tr> <td>$p_N = 100$ bar</td> <td><input type="text" value="100"/></td> <td>$p_N = 350$ bar</td> <td><input type="text" value="350"/></td> </tr> <tr> <td>$p_N = 160$ bar</td> <td><input type="text" value="160"/></td> <td></td> <td></td> </tr> </table>	$p_N = 20$ bar	<input type="text" value="20"/>	$p_N = 200$ bar	<input type="text" value="200"/>	$p_N = 63$ bar	<input type="text" value="63"/>	$p_N = 250$ bar	<input type="text" value="250"/>	$p_N = 100$ bar	<input type="text" value="100"/>	$p_N = 350$ bar	<input type="text" value="350"/>	$p_N = 160$ bar	<input type="text" value="160"/>		
$p_N = 20$ bar	<input type="text" value="20"/>	$p_N = 200$ bar	<input type="text" value="200"/>														
$p_N = 63$ bar	<input type="text" value="63"/>	$p_N = 250$ bar	<input type="text" value="250"/>														
$p_N = 100$ bar	<input type="text" value="100"/>	$p_N = 350$ bar	<input type="text" value="350"/>														
$p_N = 160$ bar	<input type="text" value="160"/>																
Standard nominal voltage U_N :	<table border="0" style="display: inline-table; vertical-align: top;"> <tr> <td>12 VDC</td> <td><input type="text" value="12"/></td> </tr> <tr> <td>24 VDC</td> <td><input type="text" value="24"/></td> </tr> </table>	12 VDC	<input type="text" value="12"/>	24 VDC	<input type="text" value="24"/>												
12 VDC	<input type="text" value="12"/>																
24 VDC	<input type="text" value="24"/>																
Hardware configuration:																	
With analog signal (0...+10 V factory set)	<input type="text" value="A1"/>																
With CANopen acc. to DSP-408	<input type="text" value="C1"/>																
With Profibus DP in accordance Fluid Power Technology	<input type="text" value="P1"/>																
With CAN J1939 (on request)	<input type="text" value="J1"/>																
Design-Index (Subject to change)																	
• Data sheet is valid from design-index #2																	

GENERAL SPECIFICATIONS

Description	Pilot operated proportional pressure relief valve with integrated electronics
Construction	Screw-in cartridge for cavity acc. to ISO 7789
Operations	Proportional solenoid wet pin push type, pressure tight
Mounting	Screw-in thread M22x1,5
Ambient temperature	-20...+65°C (typical) (The upper temperature limit is a guideline value for typical applications, in individual cases it may also be higher or lower. The electronics of the valve limit the power in case of a too high electronics temperature. More detailed information can be obtained from the operating instructions «DSV».)
Mounting position	any
Fastening torque	$M_D = 50$ Nm for screw-in cartridge $M_D = 2,6$ Nm (qual. 8.8) for solenoid screws
Weight	$m = 1,0$ kg

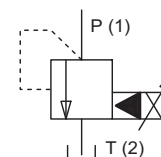
SYMBOL

HYDRAULIC SPECIFICATIONS

Fluid	Mineral oil, other fluids on request
Contamination efficiency	ISO 4406:1999, class 18/16/13 (Required filtration grade $\beta_{6...10} \geq 75$) see data sheet 1.0-50/2
Viscosity range	12 mm ² /s...320 mm ² /s
Fluid temperature	-20...+70°C
Peak pressure	$p_{max} = 400$ bar $p_{Tmax} = p_p + 20$ bar
Nominal pressure ranges	$p_N = 20$ bar, $p_N = 63$ bar $p_N = 100$ bar, $p_N = 160$ bar $p_N = 200$ bar, $p_N = 250$ bar $p_N = 350$ bar
Volume flow	$Q = 0,3...100$ l/min
Leakage volume flow	see characteristics
Repeatability	≤ 3%
Hysteresis	≤ 4%

ELECTRICAL SPECIFICATIONS

Protection class	IP 67 acc. to EN 60 529 with suitable connector and closed electronics housing
Supply voltage	12 VDC or 24 VDC
Ramps	adjustable
Parameterisation	via Fieldbus or USB
Interface	USB (Mini B) for parameterisation with «PASO» (under the closing screw of the housing cover, factory set parameters)

Analog interface:

Device receptacle (male)	M23, 12-poles
Mating connector	Plug (female), M23, 12-poles (not incl. in delivery)
Preset value signal	Voltage/Current

Fieldbus interface:

Device receptacle supply (male)	M12, 4-poles
Mating connector	Plug (female), M12, 4-poles (not incl. in delivery)
Device receptacle CANopen (male)	M12, 5-poles (acc. to DRP 303-1)
Mating connector	Plug (female), M12, 5-poles (not incl. in delivery)
Device receptacle Profibus (female)	M12, 5-poles, B-coded (acc. to IEC 947-5-2)
Mating connector	Plug (male), M12, 5-poles, B-coded (not incl. in delivery)
Preset value signal	Fieldbus

NOTE!

Detailed electrical characteristics and description of «DSV» electronics are shown on data sheet **1.13-75**.

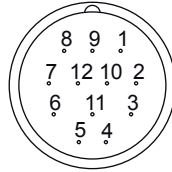
CONNECTOR WIRING DIAGRAM
Analog interface:
Device receptacle (male) X1

- 1 = Supply voltage +
- 2 = Supply voltage 0 VDC
- 3 = Stabilised output voltage
- 4 = Preset value voltage +
- 5 = Preset value voltage -
- 6 = Preset value current +
- 7 = Preset value current -
- 8 = Reserved for extensions
- 9 = Reserved for extensions
- 10 = Enable control (Digital input)
- 11 = Error signal (Digital output)
- 12 = Chassis

Preset value voltage (PIN 4/5) resp. current (PIN 6/7) are selected with set-up and diagnosis software.

Factory setting: Voltage (0...+10 V), (PIN 4/5)

CANopen interface:
Device receptacle supply (male) X1

MAIN

- 1 = Supply voltage +
- 2 = Reserved for extensions
- 3 = Supply voltage 0 VDC
- 4 = Chassis

**Device receptacle
CANopen (male) X3**

CAN

- 1 = not connected
- 2 = not connected
- 3 = CAN Gnd
- 4 = CAN High
- 5 = CAN Low

**Device receptacle
Profibus (female) X3**

PROFIBUS

- 1 = VP
- 2 = Rx/D/TxD - N
- 3 = DGND
- 4 = Rx/D/TxD - P
- 5 = Shield

Parameterisation interface (USB, Mini B) X2

Under the closing screw of the housing cover

NOTE!

The mating connectors and the cable to adjust are settings is not part of the delivery. To order the cable, look up the article no. in the chapter «Accessories».

START-UP

Normally there is no need to adjust settings by the customer. The connector has to be wired according to the chapter «Connector wiring diagram».

Additional information can be found on our website:

«www.wandfluh.com»

Free-of-charge download of the «PASO»-software and the instruction manual for the «DSV» hydraulic valves as well as the operation instruction **CANopen** eg. **Profibus DP** protocol with device profile DSP-408 for «DSV».

CHARACTERISTICS Oil viscosity $\nu = 30 \text{ mm}^2/\text{s}$

$p = f(Q)$ Pressure volume flow characteristics
 (Maximum adjustable pressure)

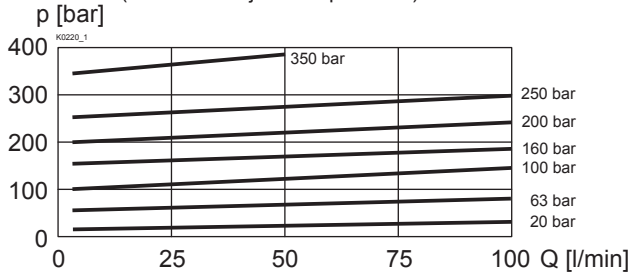

$p = f(Q)$ Pressure volume flow characteristics
 (Minimum adjustable pressure)

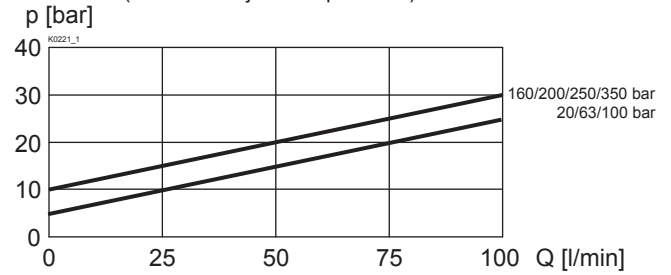

$p = f(s)$ Pressure adjustment characteristics
 [at $Q = 10 \text{ l/min}$] / (s corresponds to preset value signal)

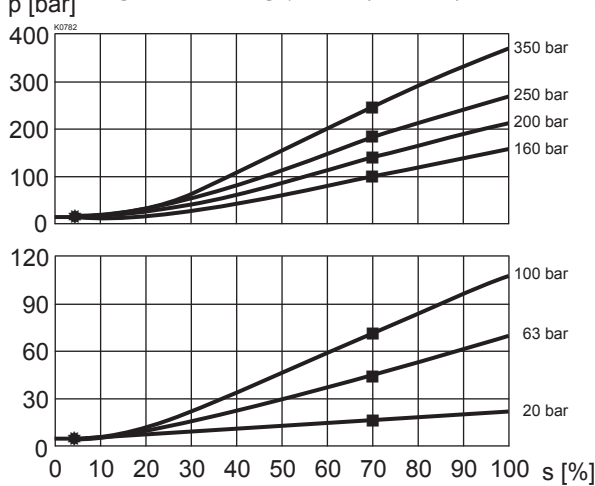

$Q_L = f(p)$ Leakage volume flow characteristics

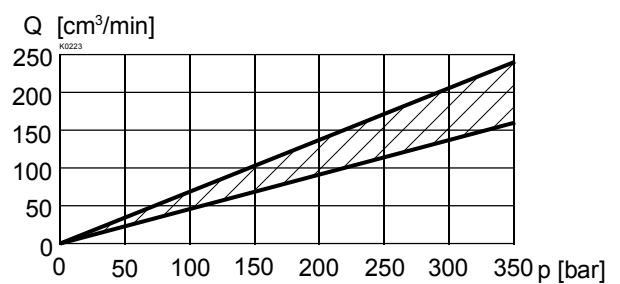
Factory settings:

Dither set for optimal hysteresis

- = Deadband: Solenoid switched off
 with command preset value signal < 5%
- = Limited pressure in port P (1) at 70% of preset value signal:
 248 bar with pressure range 350 bar
 172 bar with pressure range 250 bar
 144 bar with pressure range 200 bar
 114 bar with pressure range 160 bar
 72 bar with pressure range 100 bar
 46 bar with pressure range 63 bar
 16 bar with pressure range 20 bar

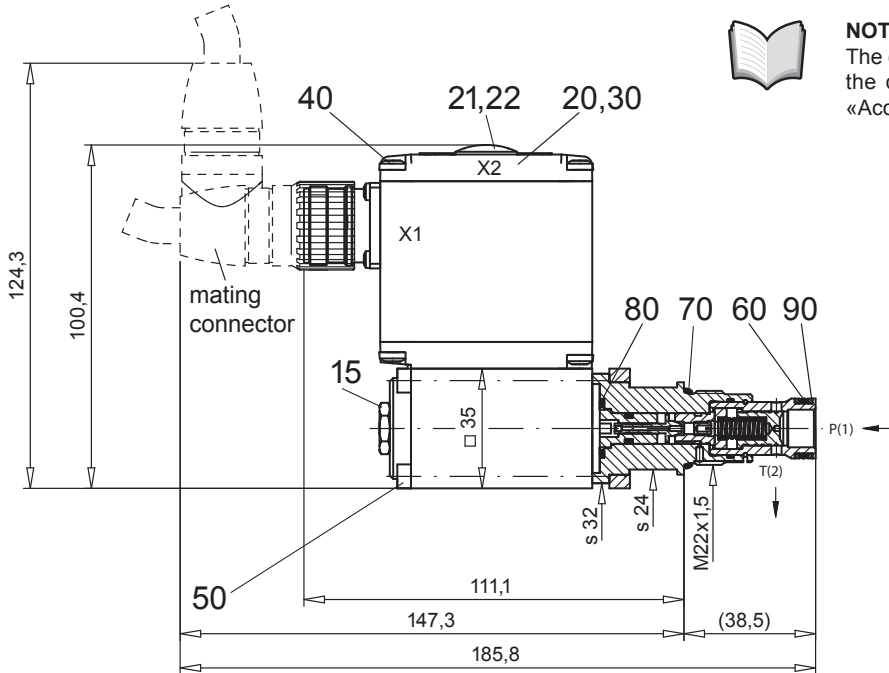
DIMENSIONS / SECTIONAL DRAWINGS
With analog interface

NOTE!

The cable connector is not part of the delivery. Regarding the dimensions see also the connector in the chapter «Accessories».

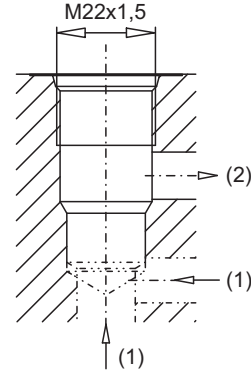
Cavity drawing according to ISO 7789-22-02-0-98

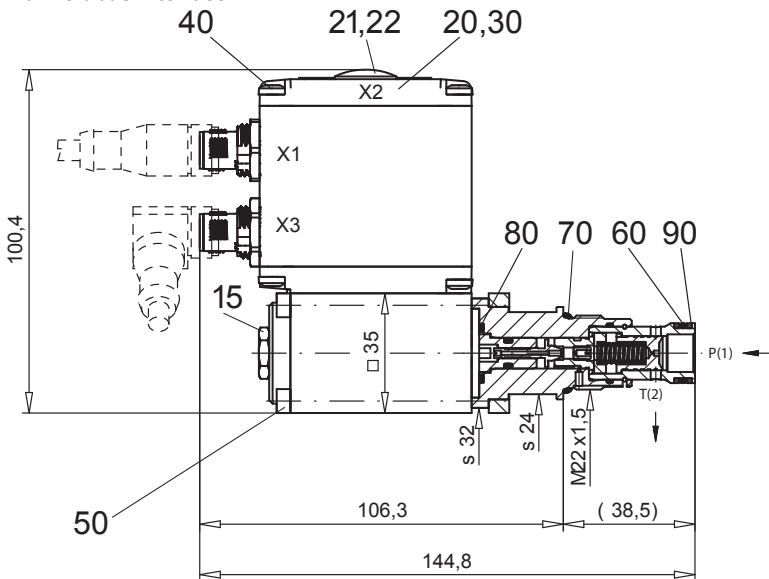

For detailed cavity drawing and cavity tools see data sheet 2.13-1003

With fieldbus interface

PARTS LIST

Position	Article	Description
15	253.8000	Mounted screw with integrated manual override HB4,5
20	062.0102	Cover square
21	223.1317	Dummy plug M16x1,5
22	160.6131	O-ring ID 13,00x1,5
30	072.0021	Gasket 33,2x59,9x2
40	208.0100	Socket head cap screw M4 x 10
50	249.1007	Socket head cap screw M4 x 63 DIN 912
60	160.2140	O-ring ID 14,00 x 1,78
70	160.2188	O-ring ID 18,77 x 1,78
80	160.2140	O-ring ID 14,00 x 1,78
90	049.3177	Back-up ring RD 14,6x17,5x1,4

ACCESSORIES

- Cartridge built-in:
 - flange and sandwich bodies see register 2.3
 - Set-up software see start-up
 - Cable to adjust the settings through interface USB (from plug type A to Mini B, 3 m) article no. 219.2896
 - Cable connector for analog interface:
 - straight, soldering contact article no. 219.2330
 - 90°, soldering contact article no. 219.2331
- Recommended cable size:**
- Outer diameter 9...10,5 mm
 - Single wire max. 1 mm²
 - Recommended wire size:
 - 0...25 m = 0,75 mm² (AWG18)
 - 25...50 m = 1 mm² (AWG17)

Technical explanation see data sheet 1.0-100